

RUBINETTO A SFERA A 2 VIE

2-WAY BALL VALVE

SCHEMA IDRAULICO
HYDRAULIC DIAGRAM

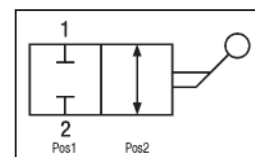

SERIE BSP e NPT

RUBINETTI A SFERA
BALL VALVES

RS2
BSP
NPT

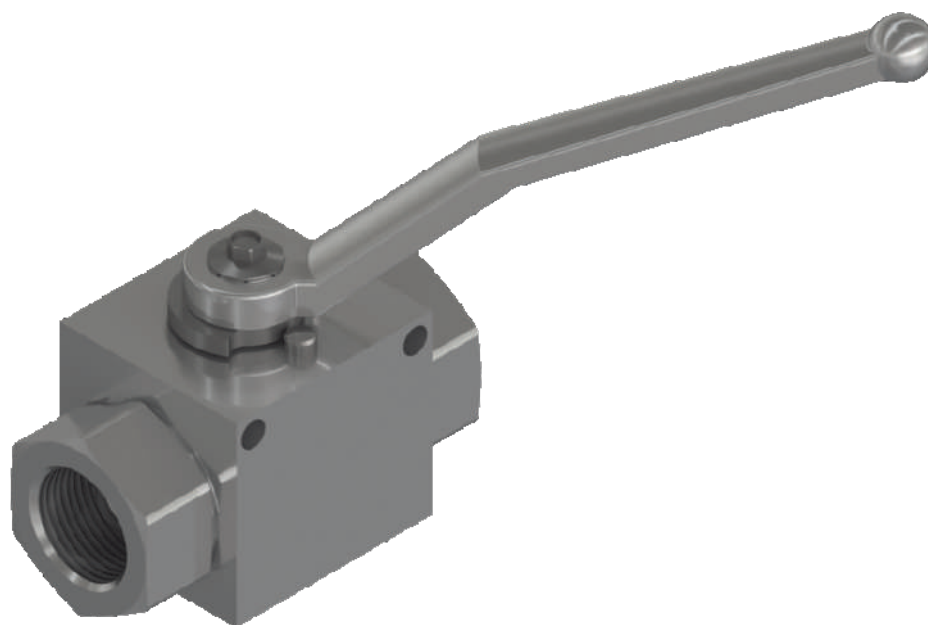

APPLICAZIONE:

È utilizzato per aprire o chiudere il flusso dell'olio, anche alla massima pressione.

NOTE COSTRUTTIVE:

Corpo: acciaio zincato
Componenti interni: acciaio cromato e zincato
Leva: Zamak
Guarnizioni: Delrin
O-Ring: NBR
Temperatura d'esercizio max: -20°C / +80°C
Non ammettono trafilamento.
Ruotano in pressione.

MONTAGGIO e FUNZIONAMENTO:

Passaggio libero del flusso con la leva in posizione 2.
Flusso bloccato completamente con la leva in posizione 1.
Collegare indifferentemente le due uscite (1 e 2) al ramo da intercettare.
La leva ruota di 90°.

A RICHIESTA:

Leve speciali - Configurazioni speciali fuori standard
Guarnizioni speciali - Zincature e trattamenti speciali.

APPLICATION:

The use of this valve is to open or close the flow in the system, even under max pressure.

FEATURES:

Body: zinc-plated steel
Internal components: chromed and zinc-plated steel
Hand lever: Zamak
Seals: Delrin
O-Ring: NBR
Maximum operating temperature: -20°C / +80°C
It does not allow any leakage.
Rotation under pressure.

MOUNTING AND OPERATION:

Free flow passage with lever in position 2.
Closed flow passage with lever in position 1.
Connect indifferently the two ports (1 and 2) to where flow has to be intercepted.
The lever rotates 90°.

UPON REQUEST:

Special levers - Special configurations out of the standard
Special gaskets - Special treatments.

PERDITE DI CARICO
PRESSURE DROPS CURVES

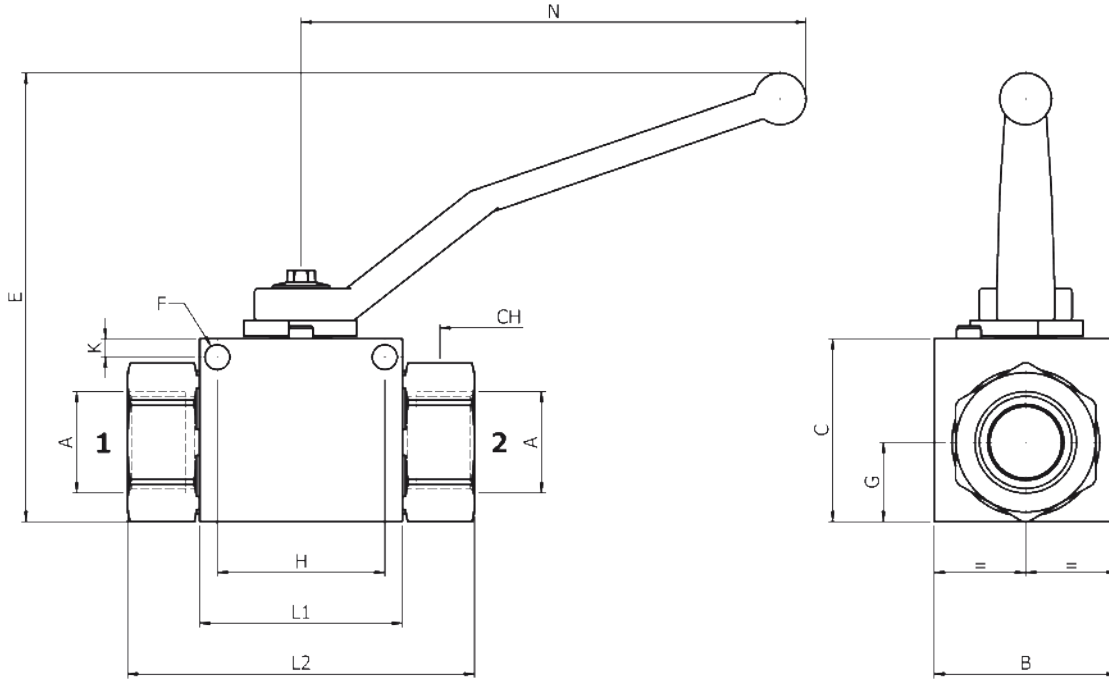
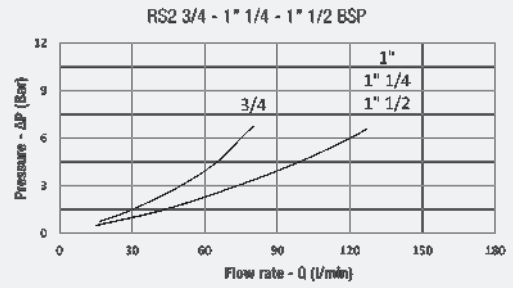
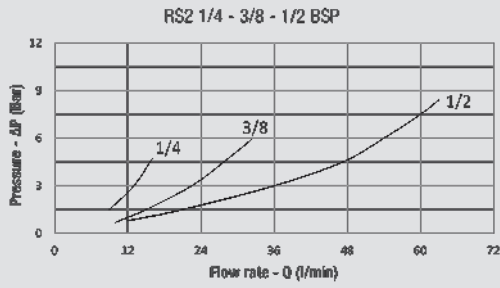

QUOTE / DIMENSIONS

TIPO / TYPE	A BSP	B	C	E	F	G	H	K	L1	L2	N	CH	PN (bar)	PESO WEIGHT kg
RS2 1/4	1/4	25	35	74	4,5	14,7	25	6	36	69	107	22	500	0,365
RS2 3/8	3/8	30	40	78	5	18,4	35	5	43	73	107	27	500	0,520
RS2 1/2	1/2	40	40	78	6	17,2	38	5	48	85	107	30	500	0,720
RS2 3/4	3/4	55	55	128	8	22,7	49	6	62,5	97	155	41	400	1,630
RS2 1"	1"	60	60	133	8	26	55	6	66,5	114	155	45	350	2,030
RS2 1" 1/4	1" 1/4	60	60	133	8	26	55	6	66,5	125	155	50	350	2,070
RS2 1" 1/2	1" 1/2	60	60	133	8	26	55	6	66,5	125	155	55	350	2,110
RS2 2"	2"	90	90	155	9	48	60	6	84,5	147	155	70	350	5,230

CODICI / CODES

BSP

NPT

TIPO / TYPE	DN	BSP		NPT	
		Senza fori fissaggio Without fixing holes	Con fori fissaggio With fixing holes	Senza fori fissaggio Without fixing holes	Con fori fissaggio With fixing holes
CODICE / CODE	CODICE / CODE	CODICE / CODE	CODICE / CODE	CODICE / CODE	
RS2 1/4	6	525 1000 000	525 1100 000	525 1000 NPT	525 1100 NPT
RS2 3/8	10	525 2000 000	525 2100 000	525 2000 NPT	525 2100 NPT
RS2 1/2	13	525 3000 000	525 3100 000	525 3000 NPT	525 3100 NPT
RS2 3/4	20	525 4000 000	525 4100 000	525 4000 NPT	525 4100 NPT
RS2 1"	25	525 5000 000	525 5100 000	525 5000 NPT	525 5100 NPT
RS2 1" 1/4	25	525 6000 000	525 6100 000	525 6000 NPT	525 6100 NPT
RS2 1" 1/2	25	525 7000 000	525 7100 000	525 7000 NPT	525 7100 NPT
RS2 2"	25	525 8000 000	525 8100 000	525 8000 NPT	525 8100 NPT